

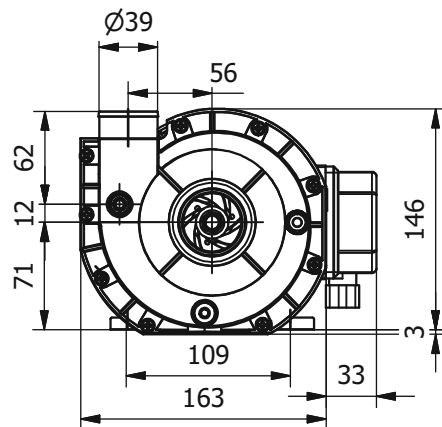

FM 4023

kW 0.64 Hm 10.9 max
HP 0.86 L/1' 362 max

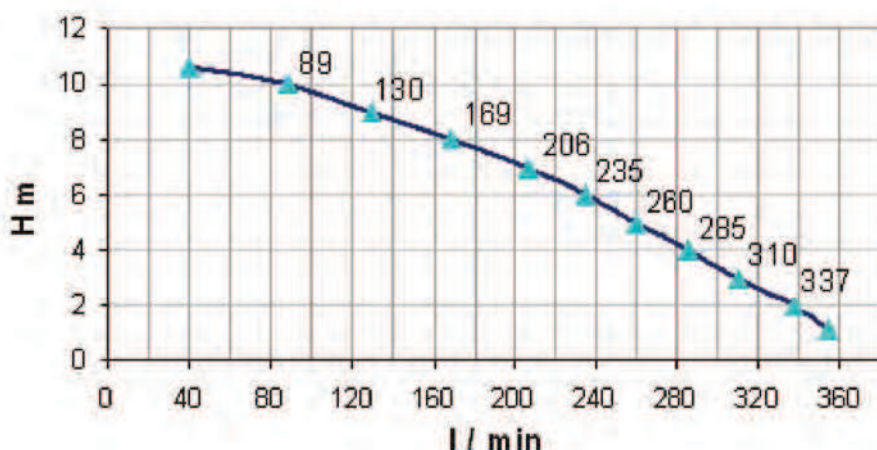
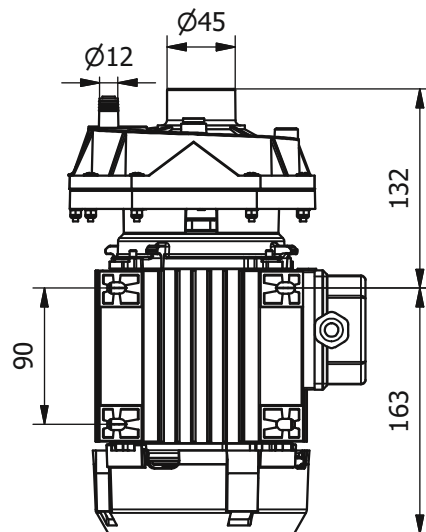
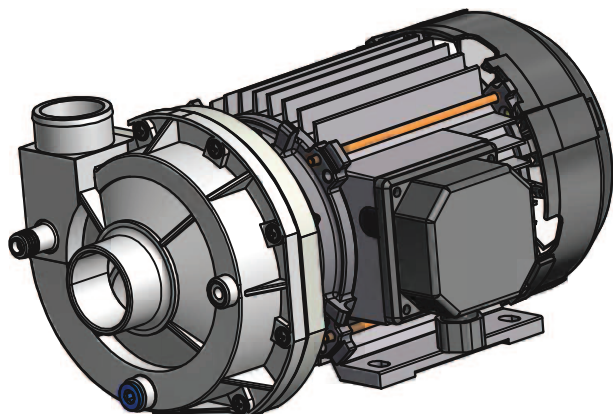

Potenza motore **HP 0.86 kW 0.64**
Motor power

Tensione (V) **230 / 400**
Tension

Frequenza (Hz) **50**
Frequency

Corrente assorbita (A) **3.26 / 1,45**
Power consumption

RPM **2800**

Condensatore (µF) **16**
Capacitor

Protezione termica (°C) **160°C**
Thermal Overload

Classe isolamento **F**
Insulation class

Grado protezione (IP) **X4**
Protection class

Servizio **S1**
Duty

Peso (kg) **7**
Weight

Materiali idraulica Wet end materials

Corpo Pompa **PP 30 GF**
Pump Body

Girante **PP 30 GF**
Impeller

Albero Motore **AISI 416**
Motor Shaft

Tenuta Meccanica **GRAFITE/CERAMICA**
Mechanical Seal CARBON/CERAMIC



Sono disponibili pompe sia con mandata a SX che a DX. Pumps with SX (left) or DX (right) pressure sides are available.

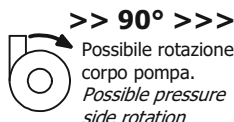

>> 90° >>>
 Possibile rotazione corpo pompa. Possible pressure side rotation

I motori standard sono conformi alle norme europee vigenti, su richiesta l'isolamento potrà essere conforme alla registrazione Underwriter Laboratories "DV-155-J E327568".

Standard motors are in conformity to Euro - Norms, on request insulations conform to Underwriter Registration E.I.S. "DV-155-J E327568" are available.

LGB si riserva il diritto di apportare modifiche tecniche in qualsiasi momento e senza preavviso. LGB reserves the right to make technical changes at any time without notice.