

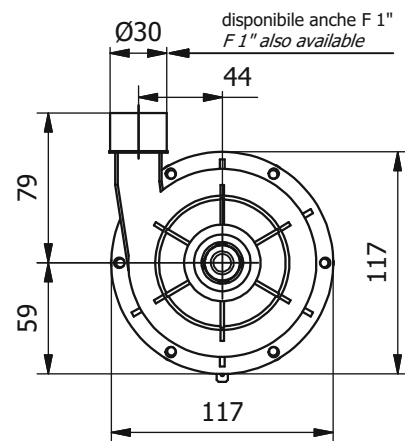

ZF 110V

kW **0.40** Hm **9** max
 HP **0.54** L/1' **132** max

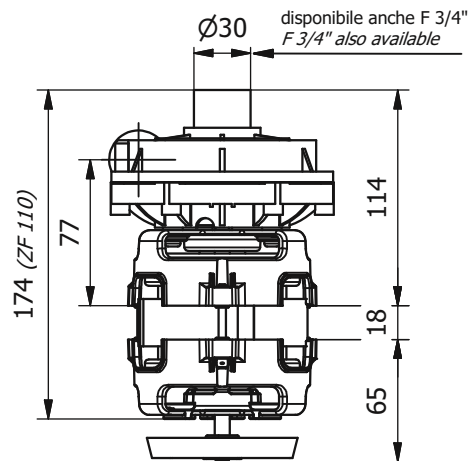
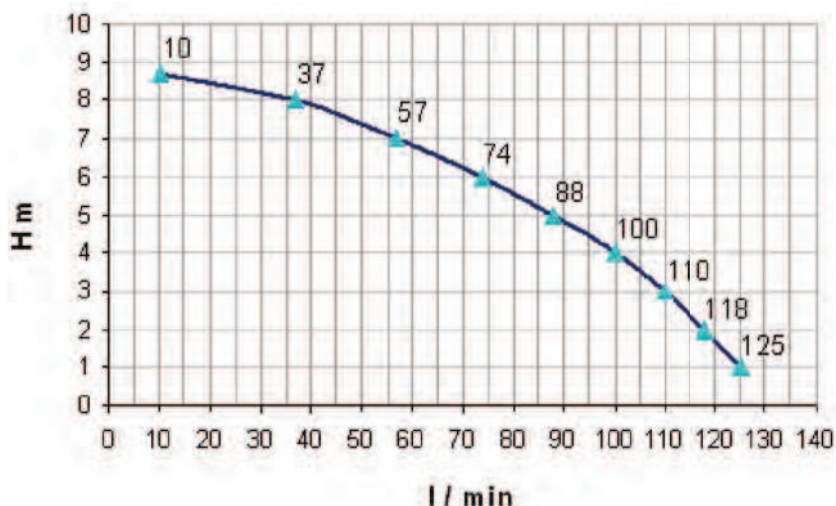
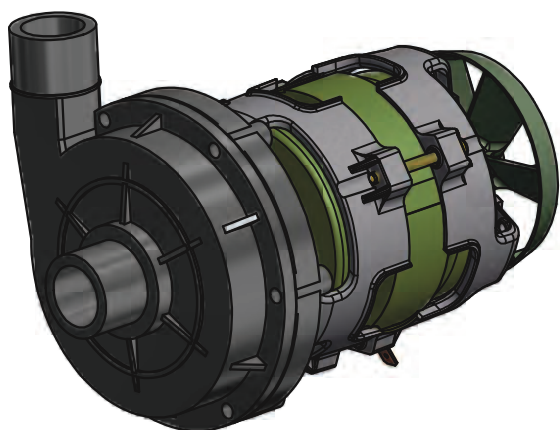

Potenza motore Motor power	HP	kW
	0.54	0.40

Tensione Tension	(V)	230
---------------------	-----	------------

Frequenza Frequency	(Hz)	50
------------------------	------	-----------

Corrente assorbita Power consumption	(A)	2.3
---	-----	------------

RPM	2800
-----	-------------

Condensatore Capacitor	(µF)	8
---------------------------	------	----------

Protezione termica Thermal Overload	(°C)	160°C
--	------	--------------

Classe isolamento Insulation class	F
---------------------------------------	----------

Grado protezione Protection class	(IP)	X0
--------------------------------------	------	-----------

Servizio Duty	S1
------------------	-----------

Peso Weight	(kg)	3.7
----------------	------	------------

Materiali idraulica Wet end materials

Corpo Pompa Pump Body	PP 30 GF
--------------------------	-----------------

Girante Impeller	PP 30 GF
---------------------	-----------------

Albero Motore Motor Shaft	AISI 416
------------------------------	-----------------

Tenuta Meccanica Mechanical Seal	GRAFITE/CERAMICA CARBON/CERAMIC
-------------------------------------	--

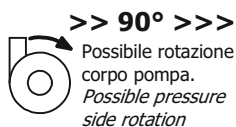

I motori standard sono conformi alle norme europee vigenti, su richiesta l'isolamento potrà essere conforme alla registrazione Underwriter Laboratories "DV-155-J E327568".

Standard motors are in conformity to Euro - Norms, on request insulations conform to Underwriter Registration E.I.S. "DV-155-J E327568" are available.

LGB si riserva il diritto di apportare modifiche tecniche in qualsiasi momento e senza preavviso.
 LGB reserves the right to make technical changes at any time without notice.